

# PRESSURE TRANSMITTER (DIRECT MOUNT TYPE)

**DATA SHEET**
**FKP...5**

The FKP model of FCX-AII V5 series of pressure transmitters accurately measures a gauge pressure and transmits a proportional 4-20 mA output signal.

The transmitter uses a unique micro-capacitive silicon sensor in combination with a state-of-the-art digital signal processing to provide exceptional performances in terms of accuracy and stability.

## FEATURES

### 1. High accuracy

Fuji Electric's micro-capacitive silicon sensor provides in standard  $\pm 0.1\%$  accuracy for all elevated or suppressed calibration ranges without additional adjustments.

### 2. Minimum inventory and design

Electronics unit, local indicators and electronics housing are interchangeable among all FCX-AII transmitters.

### 3. Minimum environmental influence

The Advanced Floating Cell technology provides a high immunity against temperature variations and overpressure commonly found in the process industry and substantially reduces the overall measurement error.

### 4. HART/Fuji Electric communication protocols

FCX-AII V5 series of pressure transmitters can communicate using either the universal HART or the proprietary and faster Fuji Electric communication protocol.

By the use of Device Description files, HART compatible devices can communicate with any FCX-AII V5 transmitter.

### 5. Application flexibility

Various options are available to address most of the process industry applications, including :

- Full range of hazardous area approvals
- Built-in RFI filter and lightning arrester
- Analog or 5 digits local display with engineering units
- Stainless steel electronics housing
- Wide selection of wetted part materials

### 6. Programmable output Linearization Function

The output signal can be linearized using up to 14 pair-points.

### 7. Burnout current flexibility

The burnout current value can be adjusted in the ranges of [3.2 ; 4.0] and [20.0 ; 22.5] mA and can be compliant with NAMUR NE43 recommendations.



## FUNCTIONAL SPECIFICATIONS

### Type :

FKP : Smart, 4-20 mA + HART/Fuji Electric communication protocols

### Service :

Liquid, gas, or vapour

### Span, range and overrange limit :

Type	Span limits kPa {bar}		Range limits kPa {bar}	Overrange limit MPa {bar}
	Min.	Max.		
FKP□01	8.125 {0.08125}	130 {1.3}	-100 to +130 {-1 to +1.3}	1 {10}
FKP□02	31.25 {0.3125}	500 {5}	-100 to +500 {-1 to +5}	1.5 {15}
FKP□03	187.5 {1.875}	3000 {30}	-100 to +3000 {-1 to +30}	9 {90}
FKP□04	625 {6.25}	10000 {100}	-100 to +10000 {-1 to +100}	15 {150}

### Lower range limit : (vacuum limit)

Silicone filling oil :

See Fig. 1

Fluorinated filling oil :

66 kPa abs (500mmHg abs) at below 60°C

### Output signal :

4-20 mA with digital signal superimposed on the analogic signal

### Power supply :

10.5 to 45 V DC at transmitter terminals.

10.5 to 32 V DC with the optional arrester.

Refer to hazardous location table for specific limitations

Load limitations : see figure below

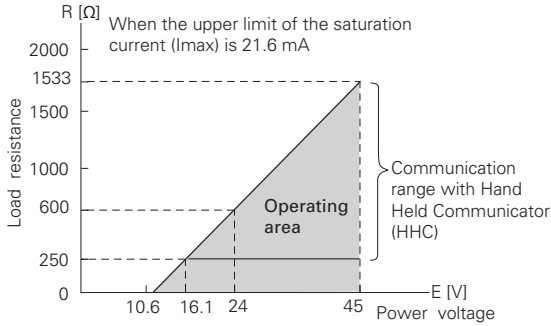

Note 1 : The load resistance varies with the upper limit of the saturation current [I max]

$$R [\Omega] = \frac{E [V] - 10.5}{(I_{max} [mA] + 0.9) \times 10^{-3}}$$

Note 2 : For communication with HHC (FXW model), a minimum load of 250 Ω is required

**Hazardous locations :**

Marking (Digit 10 =)	Protection type	
ATEX	<b>Intrinsic Safety "i" :</b>	
	Ex II 1G/D	
	Ex ia IIC T4 Ga (-40°C ≤ Ta ≤ +70°C)	
	Ex ia IIC T5 Ga (-40°C ≤ Ta ≤ +50°C)	
	Ex ia IIIC T135°C Da (-40°C ≤ Ta ≤ +70°C)	
	Ex ia IIIC T100°C Da (-40°C ≤ Ta ≤ +50°C)	
	IP 66/67	
	<b>Electrical Parameters :</b>	
	Ui ≤ 28 Vdc, li ≤ 94.3 mA, Pi ≤ 0.66 W	
	Ci = 26 nF(1) / 36 nF(2), Li = 0.6 mH(3) / 0.7mH(4)	
	(K)	<b>Flameproof Enclosure "d" :</b>
		Ex II 2G/D
		Ex d IIC T5 Gb (-40°C ≤ Ta ≤ +85°C)
		Ex d IIC T6 Gb (-40°C ≤ Ta ≤ +65°C)
		Ex tb IIIC T100°C Db (-40°C ≤ Ta ≤ +85°C)
Ex tb IIIC T85°C Db (-40°C ≤ Ta ≤ +65°C)		
45 Vdc max		
(P)	<b>Increased Safety "e" :</b>	
	Ex II 3G/D	
	Ex ec IIC T5 Gc (-40°C ≤ Ta ≤ +70°C)	
	Ex tc IIIC T100°C Dc (-40°C ≤ Ta ≤ +70°C)	
	45 Vdc max	
(M)	Combination (K) + (X)	
IECEX	<b>Intrinsic Safety "i" :</b>	
	Ex ia IIC T4 Ga (-40°C ≤ Ta ≤ +70°C)	
	Ex ia IIC T5 Ga (-40°C ≤ Ta ≤ +50°C)	
	Ex ia IIIC T135°C Da (-40°C ≤ Ta ≤ +70°C)	
	Ex ia IIIC T100°C Da (-40°C ≤ Ta ≤ +50°C)	
	IP 66/67	
	<b>Electrical Parameters :</b>	
	Ui ≤ 28 Vdc, li ≤ 94.3 mA, Pi ≤ 0.66 W	
	Ci = 26 nF(1) / 36 nF(2), Li = 0.6 mH(3) / 0.7mH(4)	
	(T)	<b>Flameproof Enclosure "d" :</b>
		Ex d IIC T5 Gb (-40°C ≤ Ta ≤ +85°C)
		Ex d IIC T6 Gb (-40°C ≤ Ta ≤ +65°C)
		Ex tb IIIC T100°C Db (-40°C ≤ Ta ≤ +85°C)
		Ex tb IIIC T85°C Db (-40°C ≤ Ta ≤ +65°C)
		45 Vdc max
(R)	<b>Increased Safety "e" :</b>	
	Ex ec IIC T5 Gc (-40°C ≤ Ta ≤ +70°C)	
	Ex tc IIIC T100°C Dc (-40°C ≤ Ta ≤ +70°C)	
	45 Vdc max	
	(Q)	Combination (T) + (R)

cCSAus		Intrinsic safety / Non Incendive / Class 1 Division 2 :
(J)		IS Class I Division 1, Groups ABCD Ex ia
		Class II Groups EFG; Class III
		NI Class I Division 2, Groups ABCD
		(Per control drawing TC522873)
		Class I Division 2, Groups ABCD
		T4 (-40°C ≤ Ta ≤ +70°C)
		T5 (-40°C ≤ Ta ≤ +50°C)
		Ui ≤ 28 Vdc, li ≤ 94.3 mA, Pi ≤ 0.66 W
		Ci = 26 nF(1) / 36 nF(2), Li = 0.6 mH(3) / 0.7mH(4)
		(E)
XP Class I Division 1, Groups CD		
Class II Groups EFG; Class III		
T5 (-40°C ≤ Ta ≤ +85°C)		
T6 (-40°C ≤ Ta ≤ +65°C)		
(L)		Vmax = 42.4 Vdc
		Combination (J) + (E)
ATEX	(W)	Combination (K) + (X) + (T) + (R) + (J) + (E)
IECEX		
cCSAus		

- (1) Without optional arrester
- (2) With optional arrester
- (3) Without analog indicator
- (4) With analog indicator

**Configuration :**

Configuration of the FCX-All V5 series of pressure transmitters can be carried out by either using a Hand Held Communicator (ie. Fuji Electric FXW or third party HART terminal) or the 3 push-buttons optional indicator. A third party HART hand held communicator can be used in combination with Fuji Electric FCX-All V5 HART Device Description files (<https://fieldcommgroup.org>).

Functions	Fuji Electric FXW		Third party HART HHC		3 push buttons optional indicator	
	Display	Set	Display	Set	Display	Set
Tag Nb	v	v	v	v	v	v
Model Nb	v	v	v	v	v	v
Serial Nb & Software revision	v	—	v	—	v	—
Engineering units	v	v	v	v	v	v
Upper Range Value	v	—	v	—	v	—
Measuring Range	v	v	v	v	v	v
Damping	v	v	v	v	v	v
Output signal type	Linear	v	v	v	v	v
	Square Root	v	v	v	v	v
Burnout current	v	v	v	v	v	v
Calibration	v	v	v	v	v	v
Output Adjust	—	v	—	v	—	v
Measuring Value	v	—	v	—	v	—
Self Diagnosis	v	—	v	—	v	—
Printer (option)	v	—	—	—	—	—
External Adj Screw Lock	v	v	v	v	v	v
Transmitter Display	v	v	v	v	v	v
Linearization	—	—	v	v	v	v
Rerange	v	v	v	v	v	v
Saturation Current	v	v	v	v	v	v
Write Protect	v	v	v	v	v	v
History	—	—	—	—	—	—
	—	—	—	—	—	—
— Calibration History	v	v	v	v	v	v
— Ambient T° History	v	—	v	—	v	—

Note 1 : The FXW firmware revision must be higher than 7.0 in order to address FCX-All V5 "Saturation Current", "Write Protect" and "History" functions.

Note 2 : The "Linearization" function is not accessible through the 3 puh-buttons optional indicator.

**Zero and span adjustment :**

Zero and span are adjustable with a Hand Held Communicator or locally with the external adjustment screw.

**Damping :**

The damping time constant can be adjusted within the range of [0.06 to 32] seconds.

**Zero elevation/suppression :**

Zero can be adjusted within the range of 0 -1 bar to 100% of the URL

**Normal/reverse action :**

Selectable from a Hand Held Communicator.

**Local indicator :**

One optional analog or 5-digits digital indicator.

**Burnout direction and saturation currents :**

If the self-diagnostic functions detect a transmitter a failure, the burnout function will drive the output signal to either "Output Hold", "Output Overscale" or "Output Underscale" modes.

When "Output Hold" :

The output signal is held as the last value just before the failure happens.

When "Output Overscale" :

The output signal is set within the range of [20.0 to 22.5] mA

When "Output Underscale" :

The output signal is set within the range of [3.2 to 4.0] mA

Both burnout and saturation current can be adjusted within the range of [3.2 ; 4.0] and [20.0 ; 22.5] mA

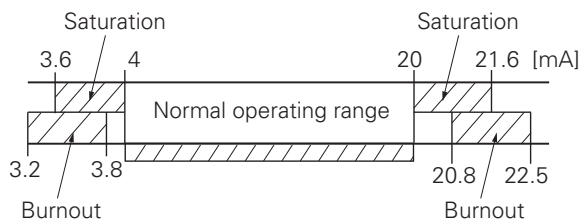
**Loop-check / fixed output current :**

The transmitter can be configured to provide a constant output signal from 3.2 up to 22.5 mA.

**Temperature limit :**

Ambient :

- 40 to +85°C

- 20 to +80°C (with optional LCD unit)

- 40 to +60°C (with optional arrester)

Please refer to the hazardous locations table for ambient temperature limitations according to the standard and type of protection.

Process :

- 40 to +100°C for silicone filling oil

- 20 to +80°C for fluorinated filling oil

Storage :

- 40 to +90°C

**Humidity limit :**

0 to 100% RH (Relative Humidity)

## PERFORMANCE SPECIFICATIONS

Reference conditions, silicone oil filling, SS 316L isolating diaphragms, 4-20 mA analog output in linear mode.

**Accuracy rating :** (including linearity, hysteresis, and repeatability)

For spans greater than 1/10 of URL:

±0.1% of span

For spans below 1/10 of URL :

± (0.05 + 0.005  $\frac{\text{URL}}{\text{span}}$ ) % of span

**Stability :**

±0.2% of URL for 10 years (In case of 6th digit code "2", "3", "4")

**Temperature effect :**

Effects per 28°C change between the limits of - 40°C and +85°C

Zero shift :

± (0.4 + 0.1  $\frac{\text{URL}}{\text{span}}$ ) % / 28°C

Total effect:

± (0.475 + 0.1  $\frac{\text{URL}}{\text{span}}$ ) % / 28°C

**Overrange effect :**

Zero shift, 0.3% of URL for any overrange to maximum limit

**Supply voltage effect :**

Less than 0.005% fo calibrated span per 1 V

**Update rate:**

60 msec

**RFI effect :**

< 0.2% of the URL for the frequencies from 20 up to 1000 MHz with an electrical field strength of 10 V/m and housing covers in place. (Classification : 2-abc : 0.2% of span according SAMA PMC 33.1).

**Response time:** (without electrical damping)

Time constant :

0.08 seconds (at 23°C)

Dead time :

About 0.12 seconds

Response time = time constant + dead time

**Mounting position effect :**

Zero shift, less than 0.1 kPa {1mbar} for a 10° tilt in any position.

This error can be corrected by adjusting zero.

(Double the effect for fluorinated fill sensors).

No effect on span.

**Vibration effect :**

< ±0.25% Of spans for spans greater than 1/10 of URL.

Frequency 10 to 150 Hz, acceleration 39.2 m/sec<sup>2</sup>

**Material fatigue :**

Please consult Fuji Electric

**Dielectric strength :**

500 V AC, 50/60 Hz 1 min., between circuit and earth (except with the optional arrester)

**Insulation resistance :**

More than 100 MΩ at 500 V DC

**Internal resistance for external field indicator :**

12Ω Max (connected to test terminal CK+ and CK-).

**Pressure equipment directive (PED) 2014/68/EU :**

According to Article 4.3

## PHYSICAL SPECIFICATIONS

**Conduit connection :**

1/2 - 14 NPT, Pg13.5, or M20 × 1.5

**Process connections :**

1/2 - 14 NPT, 1/4 - 18 NPT, Rc 1/2, G 1/2 A manometer fitting, M20 x 1.5.

**Process-wetted parts material :**

Material code (7th digit in model code)	Process cover	Diaphragm	Wetted sensor body
J	SS 316L	SS 316L + Gold coating	SS 316L
V	SS 316L	SS 316L	SS 316L

**Non-wetted parts material :**

Electronics housing :

Low copper die-cast aluminum alloy , finished with polyester coating (standard), or SS 316L (option).

Filling fluid :

Silicone oil (standard) or fluorinated oil (option)

Mounting bracket :

SS 304L

SS 316L (option)

**Environmental protection :**

IEC IP66/IP67 and Type X

**Mounting:**

Without mounting bracket :

Direct mounting on manifold (optional)

With optional mounting bracket :

For 50 mm (2") pipe or direct wall mounting

**Mass {weight} :**

Transmitter only : 1.7 kg without options.

Add : 0.3 kg for indicator

0.5 kg for mounting bracket

2.0 kg for stainless steel housing (option)

## OPTIONAL FEATURES

**Local indicator :**

A plug-in analog indicator (2.5% accuracy) can be mounted into the electronics compartment or the terminal box of the housing.

An optional 5 digit indicator with engineering units is also available.

**Local configuration with the 3 push-buttons indicator :**

A local configuration can be carried out with the optional 3 push-buttons 5-digits indicator.

**Arrester :**

A built-in arrester protects the electronics from lightning surges.

Lightning surge immunity :

±4 kV (1.2 × 50 µs)

**Oxygen service :**

Special cleaning procedures are applied during the manufacturing process to maintain oil-free all process wetted-parts.

The filling fluid is fluorinated oil.

**Degreasing :**

Process-wetted parts are cleaned and the filling fluid is standard silicone oil.

Not for use with oxygen or chlorine presence.

**NACE specification :**

Metallic materials for all pressure boundary parts comply with NACE MR 0175/ISO 15156.

SS 660 or SS 660/660 bolts and nuts comply with NACE MR 0175/ISO 15156.

**Optional tag plate :**

An extra stainless steel tag plate with customer tag data is wired to the transmitter.

**Vacuum service :**

Special silicone oil and filling procedure are applied.

## ACCESSORIES

**Hand Held Communicator :**

Model FXW, refer to datasheet n° EDS8-47

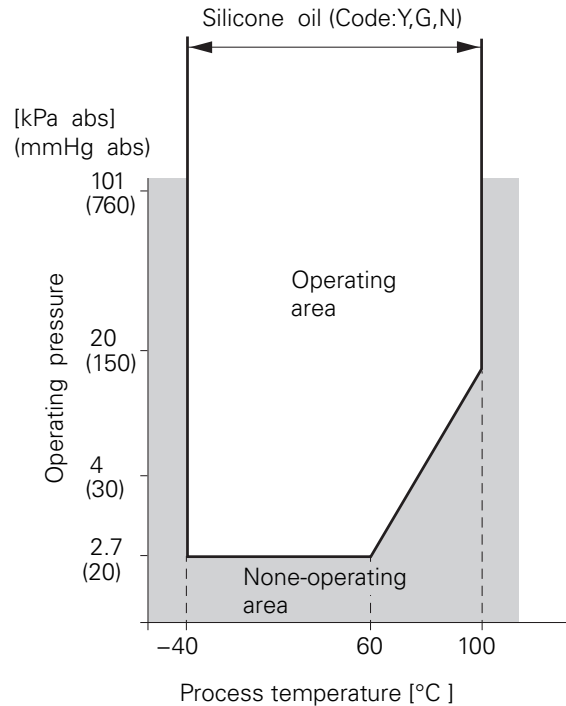

Fig.1

Relation between process temperature and operating pressure

# MODELS CODE SYMBOLS

1	2	3	4	5	6	7	8	9	10	11	12	13	14	15	DESCRIPTION	
F	K	P		0			5	-					0			Type
																Pression relative - Smart, 4-20 mA + signal numérique HART/Fuji Electric
																Connexions
																Connexion procédé
																Entrée de câbles
																Type de boîtier
T																1/2 - 14 NPT
V																Pg13,5
W																M20 x 1,5
5																G 1/2
6																1/2 - 14 NPT
7																Pg13,5
8																M20 x 1,5
																Etendue de mesure et matériaux
																Etendue de mesure
																Membrane
																Autres pièces en contact
0	1	V														Inox 316 L
0	1	J													(*4)	Inox 316 L / Dorure
0	2	V														Inox 316 L
0	2	J													(*4)	Inox 316 L / Dorure
0	3	V														Inox 316 L
0	3	J													(*4)	Inox 316 L / Dorure
0	4	V														Inox 316 L
0	4	J													(*4)	Inox 316 L / Dorure
																Indicateur
																Parasurtenseur
5	-	A														Sans
5	-	B														(*2) Analogique, 0-100%
5	-	D														(*2) Analogique, échelle client
5	-	J														(*2) Analogique, échelle double
5	-	E														Sans
5	-	F														(*2) Analogique, 0-100%
5	-	H														(*2) Analogique, échelle client
5	-	K														(*2) Analogique, échelle double
5	-	L														Numérique, 0-100%
5	-	P														Numérique, échelle client
5	-	Q														Numérique, 0-100%
5	-	S														Numérique, échelle client
5	-	1														Numérique, 0-100%, avec boutons de réglage
5	-	2														Numérique, échelle client, avec boutons de réglage
5	-	4														Numérique, 0-100% avec, boutons de réglage
5	-	5														Numérique, échelle client, avec boutons de réglage
																Agréments pour fonctionnement en zone dangereuse
A																Sans (standard)
X																(*1) ATEX - Antidéflagrant par enveloppe
K																ATEX - Sécurité intrinsèque
P																ATEX - Sécurité augmentée Ex ec
M																(*1) ATEX - Combinaison antidéflagrant par enveloppe et sécurité intrinsèque
E																(*1) cCSAus - Antidéflagrant par enveloppe
J																cCSAus - Sécurité intrinsèque et non incendive
L																(*1) cCSAus - Combinaison antidéflagrant par enveloppe, sécurité intrinsèque et non incendive
R																(*1) IECEX - Antidéflagrant par enveloppe
T																IECEX - Sécurité intrinsèque
Q																IECEX - Sécurité augmentée Ex ec
N																(*1) IECEX - Combinaison antidéflagrant par enveloppe et sécurité intrinsèque
W																(*1) IECEX - ATEX - cCSAus - Antidéflagrant par enveloppe, sécurité intrinsèque et non-incendive
																Support de montage
A																Sans
C																Avec, inox 304L
																Pièces en inox
																Plaquette repère
																Boîtier
Y																Sans
B																Avec
C																(*3) Sans
E																(*3) Avec
																Applications spéciales et liquide de remplissage
																Traitement
																Liquide de remplissage
Y																Sans (standard)
G																Dégraissage
A																Service oxygène
N																NACE
																Connexion procédé : Adaptateur soudé - Toutes les pièces en inox
																1/2 - 14 NPTI
																Rc 1/2 I
																1/4 - 18 NPTI
																1/2 - 14 NPTE
																Raccord manométrique G1/2
																M20x1,5

Notes\* :

- 1- Only with digit 4 = "T", "W", "6", "8"
- 2- Except digit 10 = "P", "Q"
- 3- SS 316L enclosure not available for "T" shape version
- 4- Gold coating on wetted parts of the measuring cell for hydrogen service

OUTLINE DIAGRAM (unit : mm)

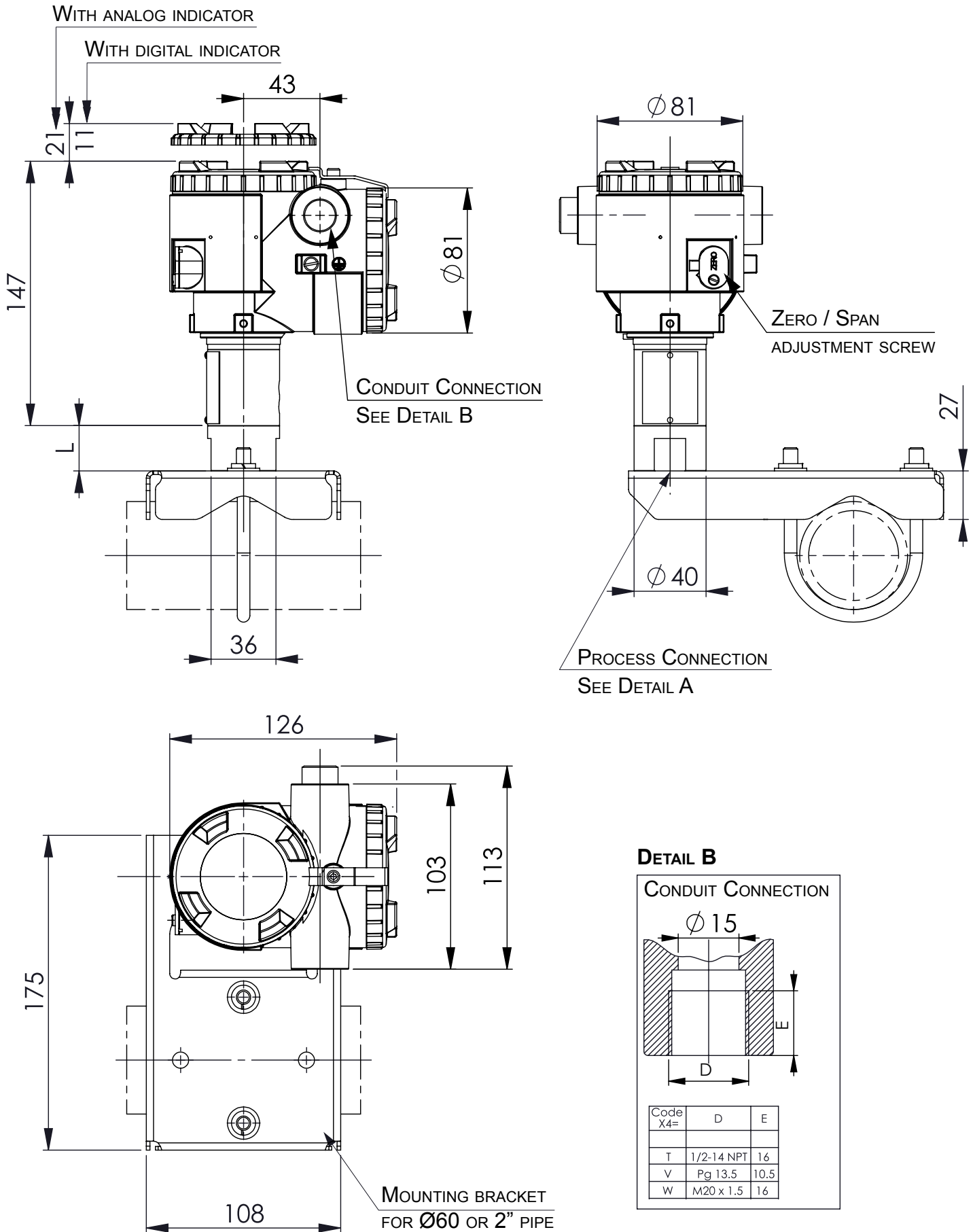

**DETAIL A**

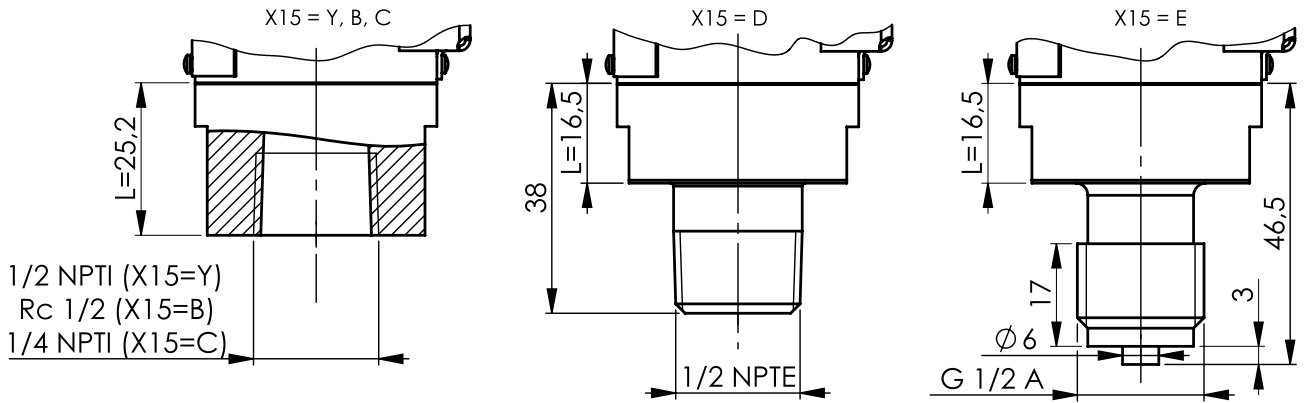

- WEIGHT :**
- 1,7 KG (WITHOUT OPTION)
- ADD :**
- 0,3 KG FOR INDICATOR OPTION
  - 0,5 KG FOR MOUNTING BRACKET
  - 2 KG FOR STAINLESS STEEL HOUSING OPTION

X <sub>1</sub> X <sub>2</sub> X <sub>3</sub> X <sub>4</sub> X <sub>5</sub> X <sub>6</sub> X <sub>7</sub> X <sub>8</sub> - X <sub>9</sub> X <sub>10</sub> X <sub>11</sub> X <sub>12</sub> X <sub>13</sub> - X <sub>14</sub> X <sub>15</sub> F K P <input type="checkbox"/> 0 <input type="checkbox"/> V 5 - <input type="checkbox"/> <input type="checkbox"/> <input type="checkbox"/> <input type="checkbox"/> <input type="checkbox"/> - 0 <input type="checkbox"/>	SPAN LIMIT	
	Min.	Max.
FKP <input type="checkbox"/> 01	8,125 kPa (0,08125 bar)	130 kPa (1,3 bar)
FKP <input type="checkbox"/> 02	31,25 kPa (0,3125 bar)	500 kPa (5 bar)
FKP <input type="checkbox"/> 03	187,5 kPa (1,875 bar)	3000 kPa (30 bar)
FKP <input type="checkbox"/> 04	625 kPa (6,25 bar)	10000 kPa (100 bar)

## CONNECTION DIAGRAM

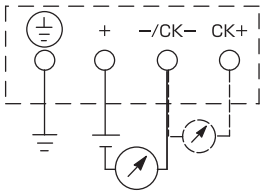

### ELECTROMAGNETIC COMPATIBILITY

All FCX-All series of pressure transmitters are in conformity with the provision of the EMC Directive 2014/30/EU on the harmonization of the laws of the Members States relating to electromagnetic compatibility.

All these models of pressure transmitters are in accordance with the following harmonized standards :

- **EN 61326-1** (*Electrical equipment for measurement, control and laboratory use - EMC requirements - Part 1: General requirements*).
- **EN 61326-2-3** (*Particular requirements - Test configuration, operational conditions and performance criteria for transducers with integrated or remote signal conditioning*).

### Emission limits (according to EN 55011 / CISPR 11, Group 1 Class A)

Frequency range (MHz)	Limits	Basic standard
30 to 230	40 dB ( $\mu\text{V/m}$ ) quasi peak, measured at 10 m distance	Passed
230 to 1000	47 dB ( $\mu\text{V/m}$ ) quasi peak, measured at 10 m distance	

### Immunity

Phenomenon	Test value	Standard	Required Performance criteria	Result of criteria
Electrostatic Discharge	$\pm 4$ kV (Contact) $\pm 8$ kV (Air)	EN/IEC 61000-4-2	<b>B</b>	<b>A</b>
Radiated, Electromagnetic Field	10 V/m (0.08 to 1.0 GHz) 3 V/m (1.4 to 2.0 GHz) 1 V/m (2.0 to 2.7 GHz)	EN/IEC 61000-4-3	<b>A</b>	<b>A</b>
Fast transients (burst)	2 kV (5/50 ns, 5 kHz)	EN/IEC 61000-4-4	<b>B</b>	<b>A</b>
Surge Transients	1 kV Line to line 2 kV Line to ground	EN/IEC 61000-4-5	<b>B</b>	<b>A</b>
Conducted RF Disturbances	3 Vrms (150 kHz to 80 MHz) 80% AM @ 1 kHz	EN/IEC 61000-4-6	<b>A</b>	<b>A</b>
Power Frequency Magnetic Field	30 A/m (50 Hz, 60 Hz)	EN/IEC 61000-4-8	<b>A</b>	<b>A</b>

Performance criteria (A & B): according to IEC 61326



### Fuji Electric France S.A.S.

46 rue Georges Besse - ZI du brézet - 63039 Clermont ferrand

Tél : 04 73 98 26 98 - Fax : 04 73 98 26 99

Mail : [sales.dpt@fujielectric.fr](mailto:sales.dpt@fujielectric.fr) - web : [www.fujielectric.fr](http://www.fujielectric.fr)